

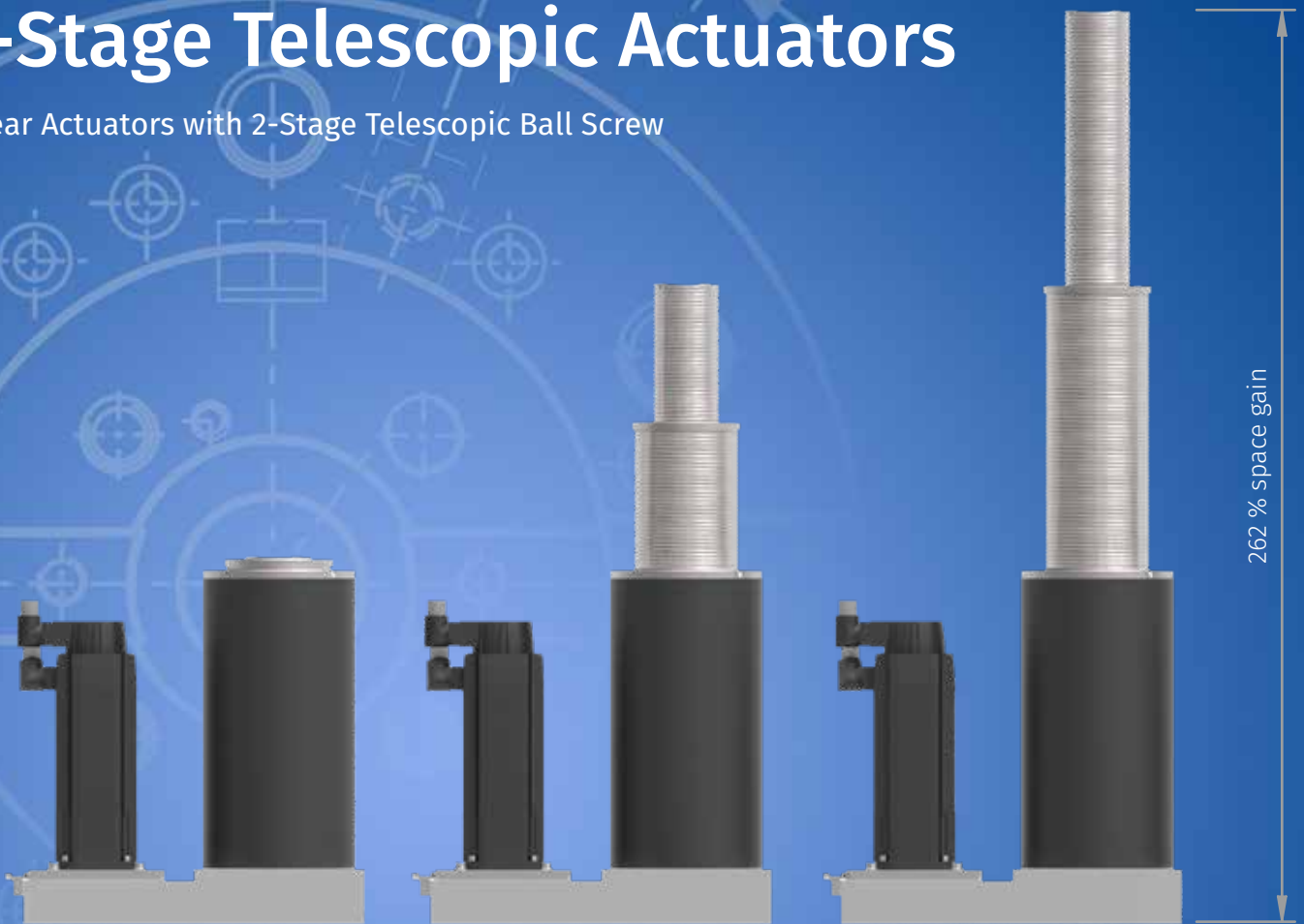

A.MANNESMANN
A member of
SCHNEEBERGER linear technology

2-Stage Telescopic Actuators

Linear Actuators with 2-Stage Telescopic Ball Screw



**Space-saving solutions
for long travel ranges in
mechanical engineering**

Greater Space Gain – Precision and High Performance

For long travel ranges with limited available space, 2-stage telescopic actuators are the right solution for a wide range of applications. The compact components offered by A.MANNESMANN provide small size and high performance precision.

A wide range of applications – delivering accuracy and high force transmission

Their compacted construction opens up a variety of possibilities. 2-stage telescopic actuators achieve accurate travel movements with machine tool precision, as well as the high force transmission required in press and fixture construction.

Outstanding space gain through 2-stage design

While achieving a space gain of up to 262 %, the patented 2-stage telescopic actuators work with extreme precision and show great axial resilience. They convert the motor's central rotary motion into an axial translatory motion by means of a telescopic ball screw.

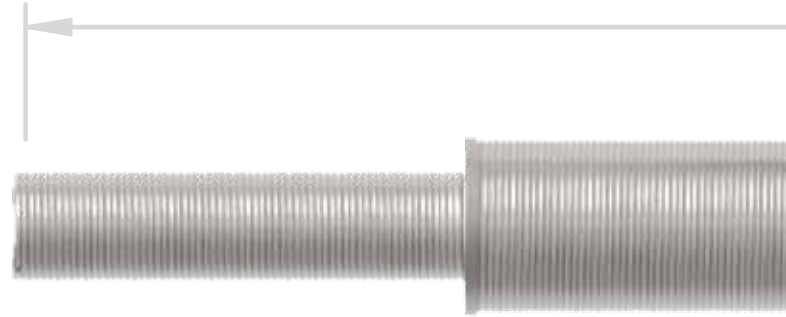

Our telescopic ball screw drives consist of two interlocked precision ball screws. The resulting partial movements are split according to the thread pitch and are perfectly synchronised.

Backlash-free, pre-loaded double nut systems in combination with precision-ground ball screw spindles in precision quality IT3 achieve the highest possible positioning accuracy and repeat accuracy.

At A.MANNESMANN perfect workmanship, the use of high-quality material and heat treatment for extreme hardness form the basis for high long-term durability.

The telescopic stages provide a constant torque and a very high efficiency rate of more than 90 %, which remain constant over the entire travel range. This means very low dissipation and stable low operating temperatures.

Economic Advantages

- Space gain through compacted construction
- High force transmission rates
- Very high efficiency (> 90 %)
- High durability/long service life
- Economical standard constructions or custom-made manufacturing
- Achieves compact engineering solutions for limited space
- Outstanding energy efficiency



Technical Advantages

- Small block dimensions
- Highest possible positioning capability and repeat accuracy
- Accurate travel movements
- High rigidity
- Long travel ranges (< 262 %)
- Backlash-free, pre-loaded double nuts
- Precision-ground ball screw spindles (precision IT3)
- Constant torque
- Very low dissipation
- Stable low operating temperatures
- Suitable for all mounting positions

Space gain 262 %

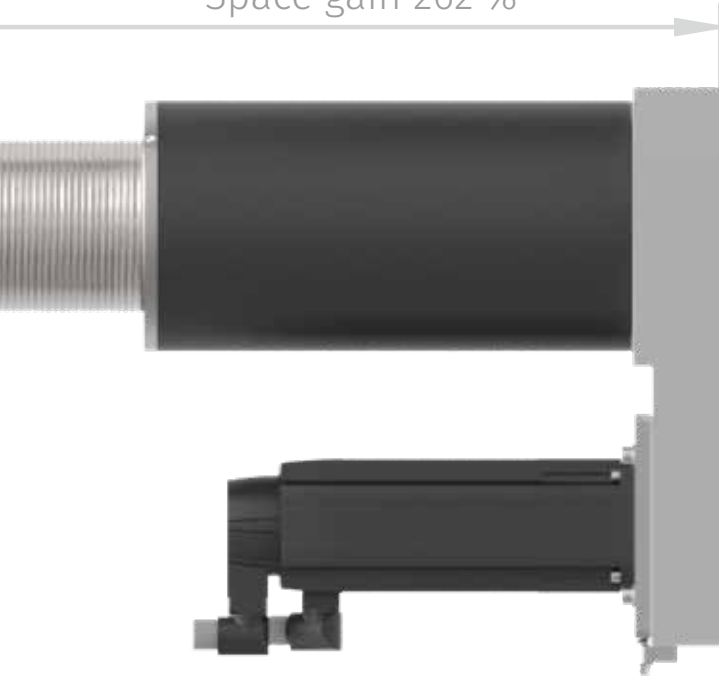

For more compact spacial requirements see our specially designed 4-stage telescopic actuators.

Please contact our specialists directly
Tel. +49 2191 989-200

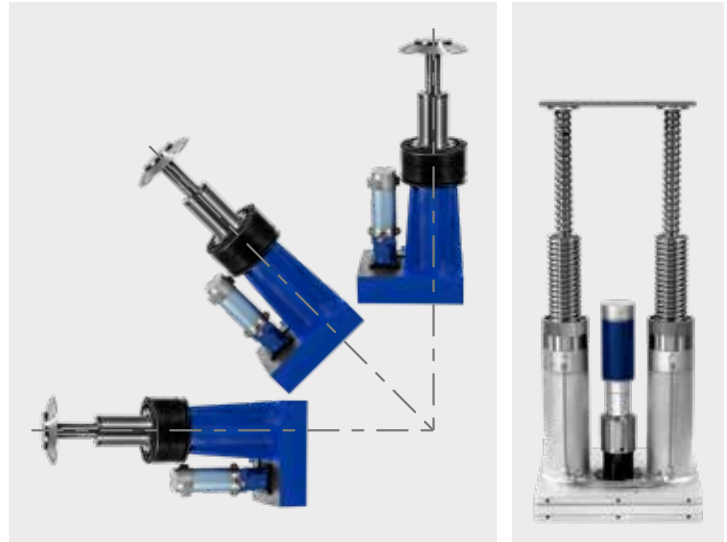

Telescopic actuators for all mounting positions

Customised manufacturing

Manufacturing and Sizes

We supply 2-stage telescopic actuators in 5 standard sizes with different travel ranges and different axial forces in both tensile and compression direction.

In addition, we produce individual special solutions for your specific requirements. We manufacture custom-made telescopic actuators with extensive accessories, tailored to suit your operating conditions perfectly.

Standard Sizes for 2-Stage Telescopic Actuators

Technical data	Type	Standard 1	Standard 2	Standard 3	Standard 4	Standard 5
Size	mm	32	40	50	63	80
Total pitch	mm	10	10	20	30	40
No. of stages		2	2	2	2	2
Pitch per stage	mm	5	5	10	15	20
Ball size	mm	3.5	3.5	6	8	10
Dynamic load rate	kN	29	34	67	110	166
Static load rate	kN	39	58	140	233	377
Max. dynamic axial load	kN	6.4	7.6	18.8	35.6	59
Max. static axial load	kN	10	14.5	35	58	94
Basic length	mm	200	220	260	300	350
Max. travel	mm	1000	1500	2000	2500	3000
Min. length *	mm	700	970	1260	1550	1850
Max. length *	mm	1700	2470	3260	4050	4850
Ratio *		2.43	2.55	2.59	2.61	2.62
Accuracy in positioning	µm	16	16	16	16	16
Max. operating speed	min ⁻¹	1500	1500	1200	1000	800
Max. linear speed	m/min	15	15	24	30	32

* In relation to maximum travel range

The A.MANNESMANN Service

For our telescopic actuators with ball screws we offer comprehensive service and support during construction, assembly and during their complete service time:

- Constructive advice
- Parameter calculation and evaluation
- Specification of optimum lubrication
- On-site support
- Support during assembly
- Damage analysis
- Overhaul and repair
- Training

We are happy to provide you personally with detailed information. You can find an overview on our website.

**A.MANNESMANN
MASCHINENFABRIK GmbH**
Bliedinghauser Str. 27
42859 Remscheid
Germany

Tel. +49 2191 989-0
Fax +49 2191 989-201
mail@amannesmann.de

www.amannesmann.de



A.MANNESMANN
A member of
SCHNEEBERGER linear technology